

Design of Wireless Capacitive Sensor to Measure the Dielectric Constant of Hematite Doped Soil

Nilofar A. Shekh¹, Jayesh P. Pabari²

¹Sardar Vallabhbhai Patel Institute of Technology, Vasad, INDIA
Physical Research Laboratory, Ahmedabad, INDIA

Abstract: This paper presented a design of Capacitive sensor for measuring impedance, based on AD5933. AD5933 IC is a high precision impedance converter system solution. The impedance measuring frequency range is between 10 kHz to 100 kHz. In this article, it is used to determine the electrical property of hematite (α -Fe₂O₃) doped soil. The real and imaginary are calibrated using a 200k components of discrete Fourier transform are recorded in order to calculate the gain factor at each frequency increment. The unknown impedances are calculated which are then utilized to calculate the complex dielectric constant of soil at each frequency. The results are verified with the experimental results of known values like air and distilled water. A wireless capacitive sensor can useful for terrestrial applications, for example, in agriculture, and also in other impedance-based applications.

Keywords: AD5933 Impedance Analyzer, Hematite, Wireless capacitive Sensor.

I Introduction and Motivation

Hematite is one of the most plentiful minerals on Earth's surface and in the shallow crust. Hematite is a chemical composition of Fe₂O₃. It is a common rock mineral found in sedimentary, metamorphic, and igneous rocks at locations throughout the world. It is the very important ore of iron. Most ore is produced in China, Australia, Brazil, India, Russia, Ukraine, South Africa, Canada, Venezuela, and the United States. As one of the two most important carriers of magnetism in the natural world, magnetic features of hematite have been well studied [3]-[6]. Most research outcomes were resulted from laboratory experiments using synthetic hematite samples. Such knowledge is very useful and important in understanding the fundamental magnetic behaviors of hematite. However, there is a gap between the magnetic behaviors of hematite contained in the natural rocks and ores and those of synthetic hematite samples [7]. The former is likely to reflect better for specific applications in the real world. Pure hematite is a composition of about 70% iron and 30% oxygen by weight. Like most natural materials, it is rarely found with the pure composition. This is particularly true of the sedimentary deposits where hematite forms by inorganic precipitation in a body of water. To measure the dielectric constant of hematite doped soil uses the impedance algorithm and calculates the impedance using AD5933 impedance Analyzer and results are plotted. For calibration purpose dielectric constant of known resistor, distilled water and air are verified.

The remaining paper is organized as follows. Section II gives details about Impedance algorithms. Section III describes the design, evaluation, and development of the Wireless Impedance Sensor, Section IV presents the experimental results and this paper ends with the conclusion and discussion.

II Impedance Algorithms

This part describes the possible capacitive Impedance algorithms.

A. Impedance Algorithm I

The simplest soil equivalent circuit shown in Fig. 1, in which capacitance accounts for the dielectric nature of bulk soil and resistance represents the leakage in it. The electrodes carry signal for the measurement of soil property. Consider soil equivalent circuit without hematite as a parallel combination of soil capacitance and soil resistance, as depicted in Fig. 1(a),

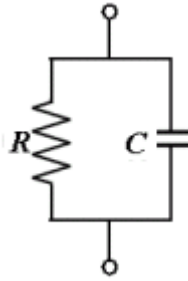

Fig 1. Soil Electrical Equivalent Circuit1

Circuit promises simplified algorithms, which are easier to be implemented for future applications. Impedance is a complex quantity given by

$$Z = Z_R + jZ_I \quad (1)$$

Where Z_R is the real part of impedance and Z_I is the imaginary parts of the impedance, respectively. Simplifying RC circuit we can obtain the real and imaginary parts of the impedance as [1]

$$Z_R = \frac{R}{1 + R^2 \omega^2 C^2} \quad (2)$$

$$Z_I = \frac{-R^2 \omega C}{1 + R^2 \omega^2 C^2} \quad (3)$$

ϵ' and ϵ'' are the real and imaginary parts of soil permittivity, respectively; and ϵ_0 is the permittivity of free space. The relative dielectric permittivity is a complex function and it is defined by the equation $\epsilon = \epsilon' + j \epsilon''$ where ϵ is the total relative permittivity, ϵ' is the real relative permittivity and it is related to the stored energy within the medium and ϵ'' is the imaginary relative permittivity and it is related to the dissipation (or loss) of energy within the medium. The real relative permittivity gives the relation with imaginary impedance as

$$\epsilon' = \frac{-Z_I}{g \omega \epsilon_0 (Z_R^2 + Z_I^2)} \quad (4)$$

The imaginary relative permittivity is related with real impedance by the equation

$$\epsilon'' = \frac{Z_R}{g \omega \epsilon_0 (Z_R^2 + Z_I^2)} \quad (5)$$

In (4) and (5) $g = A/d$ is the geometry factor of the electrode configuration, having electrode area A and interelectrode spacing d .

B. Impedance Algorithm2

In Figure 2 consider the effect of electrode resistance. It is a same structure as that of the circuit 1 in Figure 1, except the addition of the total electrode resistance (R_e) in series [8].

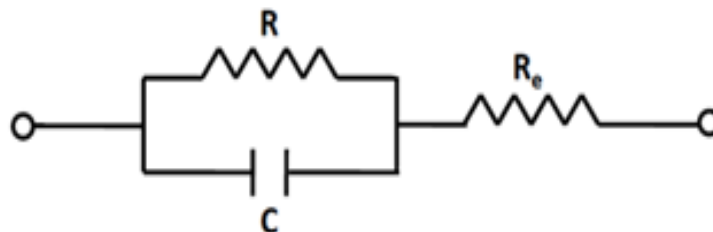

Fig 2 Soil electrical equivalent circuit2

$$Z_R = \frac{R + R_e(1 + R^2\omega^2C^2)}{1 + R^2\omega^2C^2} \quad (6)$$

$$Z_I = \frac{-R^2\omega C}{1 + R^2\omega^2C^2} \quad (7)$$

C. Impedance Algorithm3

In Figure3 represents the stray capacitance between two parallel electrodes [8].

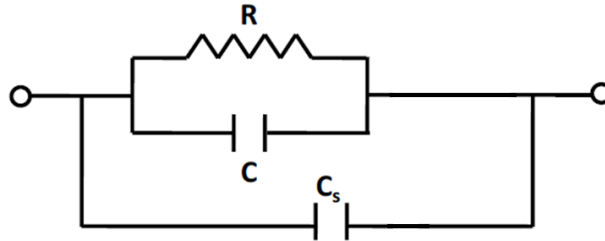

Fig 3 Soil electrical equivalent circuit3

$$Z_R = \frac{R}{1 + (\omega C + \omega^2 C^2 R)^2} \quad (8)$$

$$Z_I = \frac{R(\omega C + \omega^2 C^2 R)}{1 + (\omega C + \omega^2 C^2 R)^2} \quad (9)$$

In this paper ignore the effect of internal resistance R_e and stray capacitance C_s . Consider the method of analysis in algorithm1.

III System Design

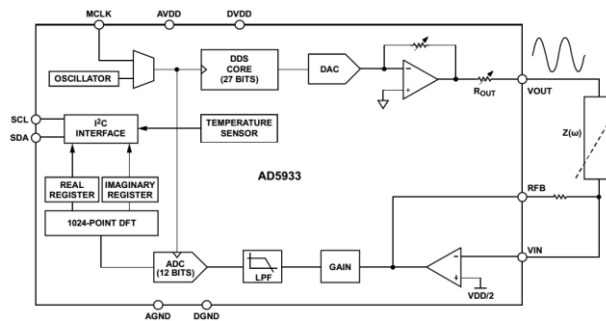

Fig 4. Schematic diagram of the Impedance Analyzer

The schematic diagram of the Impedance Analyzer from AD5933 application notes [1] is given in Fig.4. Impedance measurement performed using AD5933 impedance analyzer chip from analog devices [1]. It consists of two stages transmit and receive stages. The transmit stage uses 27 bits digital synthesizer with the aid of DAC and a programmable voltage gain stage to generate excitation voltage. The receiver stage includes current to voltage amplifier, which used with aid of programmable gain amplifier and LPF to provide suitable analog input signal to 12bits ADC. The ADC converts the received wave to digital equivalent. Finally, the DFT block used to generate real and imaginary values for received signal. Clock frequency f_{clk} for AD5933 circuit blocks is get from the internal 16.776 MHz oscillator. The clock applied to ADC block is $f_{clk}/16$ and the clock applied to DDS module is $f_{clk}/4$. In order to achieve stable excitation frequencies or low frequency, an external clock signal can be input to pin MCLK. In this system internal clock is used. The AD5933 circuit includes a temperature sensor which is used to determine the circuit temperature. This is useful to implement circuit protection and for estimation of effective frequency provided by the internal clock oscillator. The user needs to model

appropriately to extract the precise information from the impedance data. The measuring probe is connected to the sensor. Wireless capacitive sensor consists of an impedance measuring chip connected to a microcontroller, which is programmed to communicate with the sensor chip. The microcontroller is programmed using a computer through a Universal Serial Bus port. Data are stored in the memory for further use. An RF transceiver, capable of communicating in wireless mode at a 2.4 GHz frequency in the Industrial, Scientific and Medical (ISM) band, is connected to the microcontroller. The data stored in memory are transmitted to the data aggregator in wireless mode by the transceiver through an antenna. The detailed design is depicted in Fig.5. Data on the SD card are recorded in comma or tab separated value format to be easily processed in mathematical software, such as Microsoft Excel.

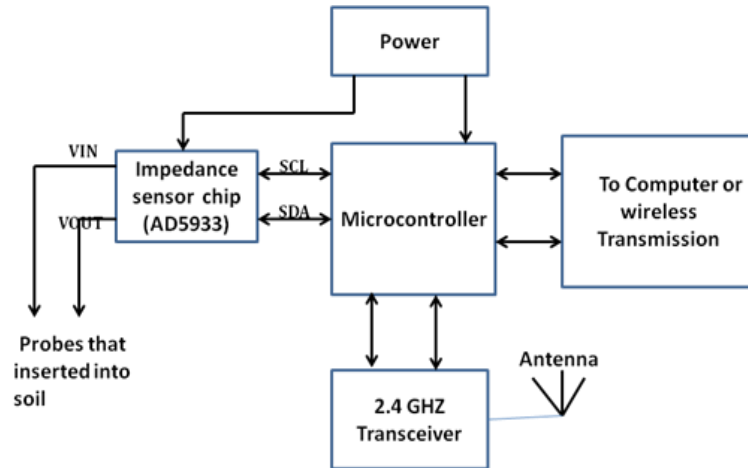

Fig 5. Block diagram of Wireless Capacitive Sensor

IV Experiment Results

1. Resistor:

The Ad5933 impedance Analyzer initially calibrated using 200kΩ Resistor and result is shown in fig 6.

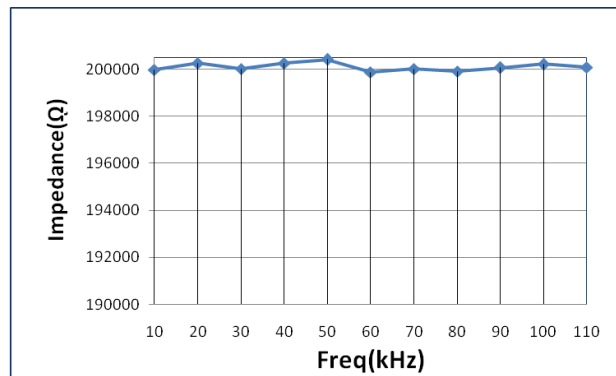

Fig 6. Impedance of 200kΩ Resistor

2. Air and Distilled Water

Before the measurement of unknown material, first results are verified with known value. So measure the dielectric constant of air and distilled water and verify the results are as shown in fig 7 and 8. The purpose of testing known value was only to establish the technique early evaluation of the sensor. Results are good agreement [9] given in figures. The two electrodes were made for testing, and two bare copper wires are used as electrodes.

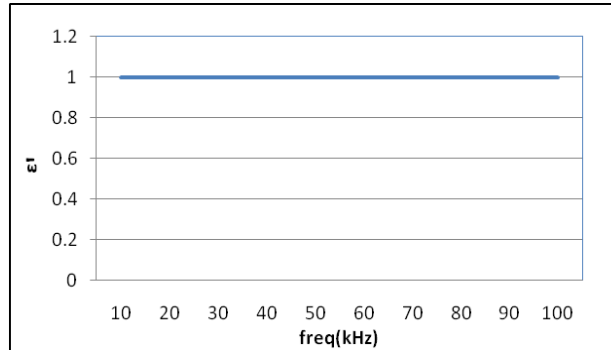

Fig.7. Real Relative Permittivity of Air

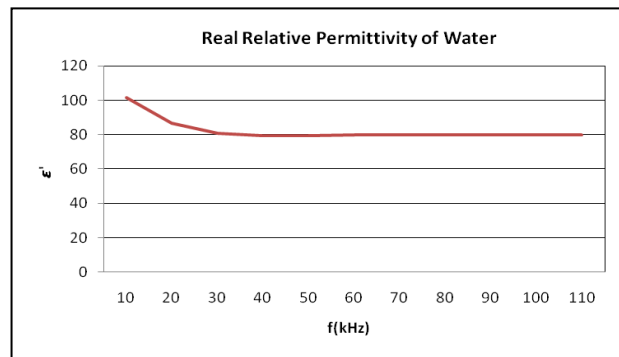

Fig.8. Real Relative Permittivity of Water

3. Hematite

The dielectric constant of Fe_2O_3 is shown in fig.9.

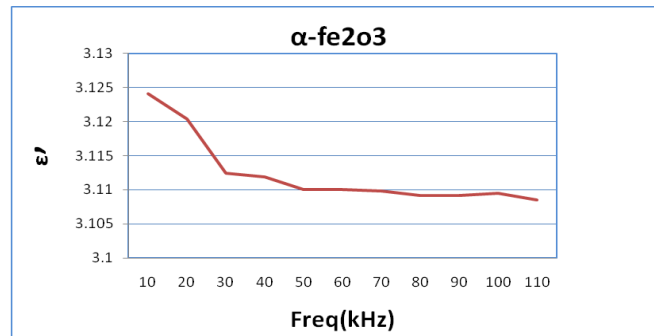

Fig.9. Real Relative Permittivity of Hematite

4. Sand and doped with hematite

The results presented in Fig. 10 obtained where hematite was added to the sand in amounts ranging from 5Wt%, 10wt% and 20 Wt%.

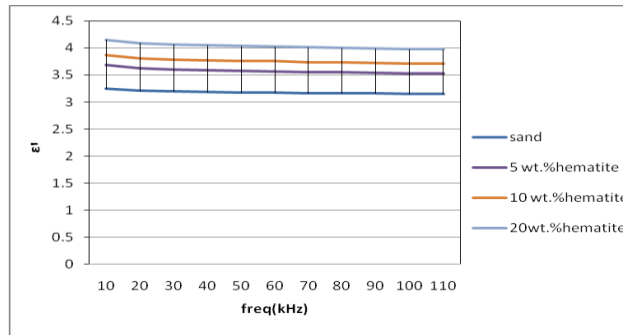

Fig.10. Real Relative Permittivity of hematite doped soil

IV Conclusion

This paper presents the results from an analysis of a soil by doping the hematite over the frequency range of 10 kHz to 100 kHz. The user has to use an appropriate model to extract the precise information from the impedance data. A portable low cost impedance sensor was designed and implemented. The device can be left in the field to do continuous measurements for around 24 hours and the data can be obtained wirelessly afterwards. In agriculture the availability of such an impedance analyzer makes it possible to determine a lot of information about the soil. It is observed that the dielectric constant of sand is decreases with frequency. It is also observed that the % of weight of hematite increases the dielectric constant of sand is also increases.

References

1. Analog Devices, "1 MSPS, 12-Bit Impedance Converter, Network Analyzer [Online]. Available: http://www.analog.com/media/en/technical_documentation/data-sheets/ad5933.pdf
2. Liviu Breniuc and Valeriu David" Wearable Impedance Analyzer Based on AD5933", 2014 International Conference and Exposition on Electrical and Power Engineering (EPE 2014), 16-18 October, Iasi, Romania, 2014 IEEE
3. Merrill, R.T., McElhinny, M.W. and McFadden, P.L. (1996) *The Magnetic Field of the Earth: Paleomagnetism, the Core, and the Deep Mantle*. Academic Press, San Diego.
4. Tarling, D.H. and Hrouda, F. (1993) *The Magnetic Anisotropy of Rocks*. Chapman & Hall, London.
5. Dunlop, D.J. and Ozdemir, O. (1997) *Rock Magnetism*. Cambridge University Press, Cambridge. <http://dx.doi.org/10.1017/CBO9780511612794>
6. Butler, R.F. (1992) *Paleomagnetism*. Blackwell Scientific Publications, Boston
7. William W. Guo "A Study of Rock Magnetism of High-Grade Hematite Ores", *Journal of Applied Mathematics and Physics*, 2015, 3, 156-160
8. V. M. Gohil, J. P. Pabari, S. R. Panchal, V. H. Nayak," Effect of Electrode Resistance and Stray Capacitance on Measurement of Soil Properties", *IOSR Journal of Engineering*, Apr. 2012, Vol. 2(4) pp: 837-843
9. F. Grasso, F. Musumeci, and A. Triglia, "Impedance spectroscopy of pure water in the 0.01 Hz to 100 kHz range," *IL Nuovo Cimento D*, vol. 12, no. 8, pp. 1117-1130, Aug. 1990.