

INTERFERENCE-AWARE ROBUST TOPOLOGY DESIGN IN MULTI-CHANNEL WIRELESS MESH NETWORKS

Geeta Y. Midha¹ and R.K. Krishna²

¹(CS&E) RCERT, Chandrapur, MS. India, E-mail:geeta_midha@rediffmail.com

²Dept. of Electronics, RCERT Chandrapur, M.S. India, E-mail: rkrishna40@rediffmail.com

ABSTRACT

The performance of wireless networks can be significantly improved by multi-channel communications compared with single-channel communications since the use of multiple channels can reduce interference influence. In this paper, we study interference-aware topology control in IEEE 802.11-based multichannel wireless mesh networks with dynamic traffic. Channel assignment is one of the most basic and important issues in such networks. Different channel assignments can lead to different network topologies.

Over the last decade, the paradigm of Wireless Mesh Networks (WMNs) has matured to a reasonably commonly understood one, and there has been extensive research on various areas related to WMNs such as design, deployment, protocols, performance, etc. The quantity of research being conducted in the area of wireless mesh design has dramatically increased in the past few years, due to increasing interest in this paradigm as its potential for the “last few miles”, and the possibility of significant wireless services in metropolitan area networks.

This recent work has focused increasingly on joint design problems, together with studies in designing specific aspects of the WMN such as routing, power control etc. in isolation.

INTRODUCTION

These networks provide relatively high-performance wireless accesses, and are widely adopted at homes, in offices, and hotspot areas in cities. A wireless mesh network is a multihop wireless network consisting of a large number of wireless nodes, some of which are called gateway nodes and connected with a wired network.

It has attracted much research attention due to its potential applications, including last-mile broadband Internet access, neighborhood gaming, Video-on-Demand (VoD), distributed file backup, video surveillance and so on. Due to the limited channel capacity, the influence of interference, the large number of users and the emergence of realtime multimedia applications, improving network capacity have become a critical requirement in such networks.

One common technique used to improve overall network capacity is use of multiple channels. Using multiple channels instead of a single channel in multihop wireless networks has been shown to be able to improve the network throughput dramatically.

The architecture of a multi-channel wireless mesh network is shown in Figure 1. The network capacity improvement in such networks is brought mainly by allowing multiple simultaneous transmissions within a neighborhood. However, in a multi-channel network, no collision will be caused by such simultaneous transmissions as long as they work on different channels.

We want the channels assigned to the NICs in a common neighborhood to be as different as possible such that interference can be reduced. In addition, we need to preserve the network connectivity and support survivability.

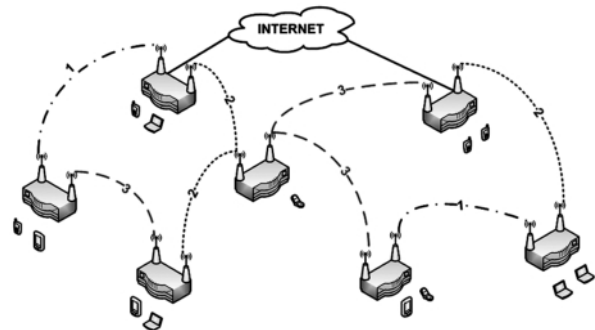

Figure 1: Wireless Mesh Network Architecture

In this paper, based on the novel definition of co-channel interference which can capture the impact of interference precisely [20], by fully considering both interference and connectivity, we define the *interference-Aware Robust Topology (I-ART)* problem which seeks network topology design and a channel assignment such that the induced network topology has the minimum network interference among all 2-connected topologies.

In this work, 2-connectivity is required for survivability and load-balancing purposes. We assume the transmission power of each NIC is fixed. So the topology

control problem studied here is quite different from all previous topology control problems in which the network topology is controlled by carefully adjusting.

WMN GENERAL CHARACTERISTICS

WMN do not require centralized access points to mediate the wireless connection WMN Multi-hop feature – increases the coverage area and link robustness of existing Wi-Fi's; (if the correspondent nodes are not in the wireless transmission range of each other) Hope to complement and improve the performance/costs for WPANs, MANETs, WLANs, WMANs, WMNs are in significant progress; numerous deployments already exist, to deliver wireless services for a large variety of applications in personal, local, campus, and metropolitan areas WMNs wireless nodes: mobile or fixed Basic types of nodes: *mesh routers* (MR) and *mesh clients* (MC), where MR – establishes an infrastructure backbone for clients Actually one have: *Wireless Mesh routers, Gateways, Printers, Servers, Mobile or Stationary clients* (terminals)

Basic Architectures and Challenges Infrastructure/ Backbone WMNs Mesh Routers (MR) :

Compose together a mesh infrastructure/bacbone for clients (connected to them) using different RT (mainly 802.11) Actually one has a wireless distribution system replacing the wired one in 802.11 MRs form a mesh of self-configuring with self-healing links MR/GW: additional gateway/bridge functionality, for connection to the Internet Clients with Ethernet I/F can be connected to MRs via Ethernet links Clients with the same radio technologies as MRs - can directly communicate with MRs.

LITERATURE REVIEW

- Interference-Aware Robust Topology Design in Multi-Channel Wireless Mesh Networks

Paper is based on the novel definition of co-channel interference which can capture the impact of interference by fully considering both interference and connectivity, we define the *Interference-Aware Robust Topology* I-ART) problem which seeks network topology design and a channel assignment such that the induced network topology has the minimum network interference among all 2-connected topologies.

In this work, *2-connectivity is required for survivability and load-balancing purposes*. We assume the transmission power of each NIC is fixed. So the topology control problem studied here is quite different from all previous topology control problems [3][13] in which the network topology is controlled by carefully adjusting the transmission power at each node.

The authors developed a set of centralized algorithms for channel assignment, bandwidth allocation, and routing.

(Potential Interference Edge)

It is impossible to calculate the interference suffered by each edge. However, because the interference edges will be a subset of the potential interference edges, if we can reduce the number of potential interference edges, we could reduce the interference in the network.

(Interference edge):

Given a channel assignment A and its corresponding network topology GA , for any two potential interference edges (u, v) and (x, y) , if there is a channel $k \in A(u) \cap A(v) \cap A(x) \cap A(y)$, then the link $(u, v; k)$ interferes with the link $(x, y; k)$, since simultaneous transmissions along $(u, v; k)$ and $(x, y; k)$ will lead to collision.

$(x, y; k)$ is an interference edge to $(u, v; k)$, and vice versa.

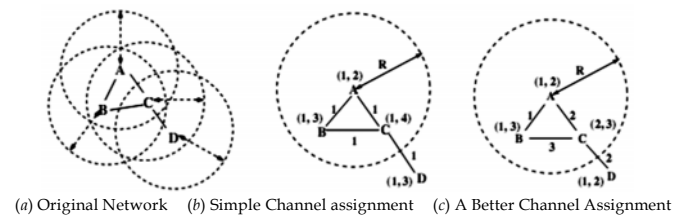

Figure 2: Interference-aware Topology Design

(Network Interference):

Given the network G , and a channel assignment A , the *network interference* is defined as the *maximum edge interference number* among all the edges in network GA , which is $\max_{e \in GA} \text{GAIN}(e)$.

(I-ART Problem):

Given the network G , the Interference-Aware Robust Topology (I-ART) problem seeks a channel assignment A such that the corresponding network topology GA is 2-connected (robust to any single failure) and has the minimum network interference.

It is worth noting that by minimizing the network interference, I-ART aims to minimize the maximum interference suffered by any edge in the network. We try to assign the channel evenly throughout the network, and consequently generate a more robust and balanced network in terms of interference suffered at each edge.

- Our aim to find a subgraph G of network G .
- G is expected to be 2-connected and has the minimum number of edges.
- The idea behind this is that the less number of edges in the network,
- the less potential interferences between edges.
- Consequently, the less network interference.

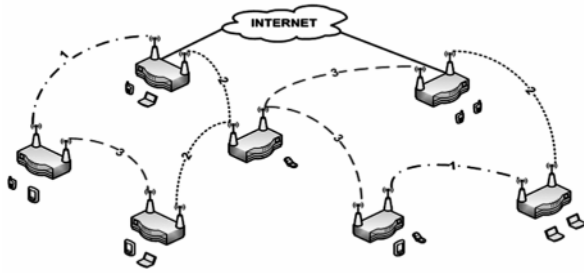

- The architecture of a multi-channel wireless mesh network is shown in above figure.
- The network capacity improvement in such networks is brought mainly by allowing multiple simultaneous transmissions within a neighborhood. 2nd paper is Architecting a High-Capacity Last-Mile Wireless Mesh Network.

2nd paper is Architecting a High-Capacity Last-Mile Wireless Mesh Network

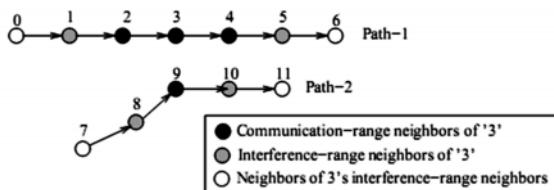

Figure 3: Intra-path and Inter-path interference in a single-channel multihop ad hoc network. Node 1, 2, 4, 5 are in the interference range of Node 3, and hence cannot transmit/receive when Node 3 is active. Node 8, 9, and 10 belonging to another node-disjoint path also fall in the interference range of Node 3. Thus none of the wireless links shown in the figure can simultaneously operate when Node 3 is transmitting to Node 4.

Performance:

- We conducted NS-2 simulations to gauge the improvements in network goodput with the use of multichannel mesh networking. We constructed 10 different 60-node network topologies, each randomly sampled from a 9×9 square grid network, and deployed four gateway nodes across each network. For each topology, 30 of the nodes were chosen at random to generate traffic streams. Each node in the network is equipped with 2 NICs, and the number of physical channels is 12. For each experiment, we measure the aggregate end-to-end throughput achieved by the network.

With the proposed distributed channel assignment algorithm, the network throughput becomes 6 to 7 times that of single-channel network.

Intuitively, *Hyacinth's* channel assignment algorithm breaks a collision domain in a single-channel network into multiple collision domains each operating in a different frequency range.

This *division of collision domain across different frequency channels* is the key reason for the nonlinear goodput improvement (6-7 times) with respect to the increase in the number of NICs (from 1 to 2). Moreover, the interference among adjacent hops of an individual path and among neighboring paths is greatly reduced.

Paper 3: Centralized Channel Assignment and Routing Algorithms for Multi-Channel Wireless Mesh Networks

The band-width problem is further aggravated for multi-hop ad-hoc networks because of interference from adjacent hops in the same path as well as from neighboring paths [1]. Figure 1 shows an example of such interference.

Fortunately, the IEEE 802.11b/802.11g standards [2] and IEEE 802.11a standard [3] provide 3 and 12 non-overlapping frequency channels, respectively, that could be used simultaneously within a neighborhood. Ability to utilize multiple channels within the same network substantially increases the effective bandwidth available to wireless network nodes.



Figure 4: Intrapath and Inter-path Interference in a single channel multi-hop adhoc network

Node 1,2,4,5 are in the interference range of node 3, and hence cannot transmit/receive when node 3 is active.

Node 8,9,10 belonging to another node-disjoint path also fall in the interference range of node 3.

In this paper,

We propose and evaluate one of the first multi-channel multi-hop wireless ad-hoc network architectures that can be built using standard 802.11 hardware by equipping each node with multiple network inter-face cards (NICs) operating on different channels.

The architecture does not perform channel switching on a packet-by-packet basis; our channel assignment lasts for a longer duration, such as hours or days, and hence does not require re-synchronization of communicating network cards on a different channel for every packet.

The Channel Assignment Problem

The goal of channel assignment in a multi-channel wireless mesh network is to bind each network interface to a radio channel in such a way that the available bandwidth on each virtual link is proportional to its expected load.

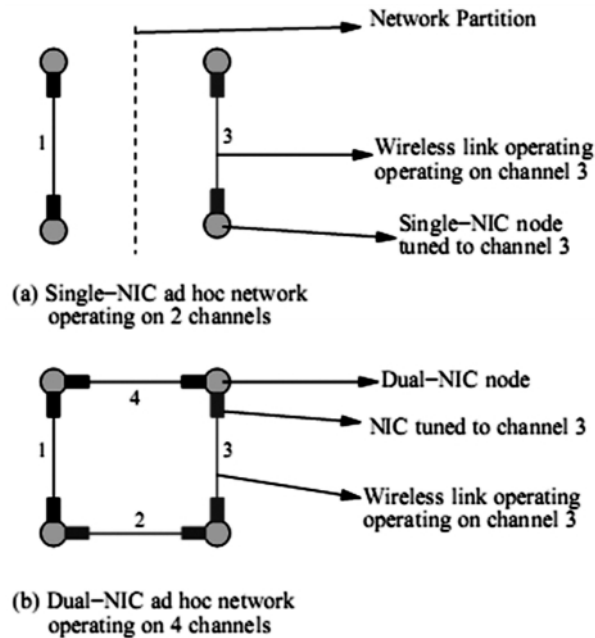

Figure : (a) Single-NIC Network Gets Disconnected when Operating in Multiple Channels, (b) Even Placing 2 NICs on each Network Node Enables Forming a Connected 4-Channel Networks

A simple approach to the channel assignment problem is to assign the same set of channels to the interfaces of each node, e.g., channel 1 to the first NIC, channel 2 to the second NIC.

This *identical channel assignment* indeed provides throughput gains by utilizing multiple channels.

Acknowledgment

_ Materials of this tutorial are based on several authors' work and literature; among the main ones are the following overviews and tutorials and studies:

- [1] W. Zhang, G. Xue, J. Tang, and K. Thulasiraman, "Faster Algorithms for Constructing Recovery Trees Enhancing QoS and QoS", *IEEE/ACM Transactions on Networking*, **16**, (2008), pp. 642-655.
- [2] Ekram Hossain, Kin Leung Editors, "Wireless Mesh Networks Architectures and Protocols", Springer, 2008.
- [3] J.C. Hou, et.al., "Medium Access Control and Routing Protocols for WMN", *Ch. in Wireless Mesh Networks Architectures and Protocols*, Springer, 2008.
- [4] Sichitiu M.L., "Wireless Mesh Networks: Challenges and Opportunities", 2006, www.ece.ncsu.edu/wireless/MadeInWALAN/wmnTutorial.ppt
- [5] Mohapatra P., *Wirelessmesh Networks*, <http://www.embeddedwisents.org/dissemination/-pres/padova-mesh-tutorial.pdf> Conner, S.W., IEEE 802.11s Tutorial, Overview of the Amendment for Wireless Local Area Mesh Networking, IEEE802 Plenary, Dallas, Nov, 2006.
- [6] I.F. Akyildiz, X. Wang, W. Wang, "Wireless Mesh Networks: A Survey", *Elsevier Journal of Computer Networks*, **47(4)**, 2005, pp. 445-487.
- [7] J. Tang, G. Xue, and W. Zhang, "Interference-Aware Topology Control and QoS Routing in Multi-Channel Wireless Mesh Networks", *ACM MobiHoc'2005*, pp. 68-77.
- [8] M. Burkhart, P. Von Rickenbach, R. Wattenhofer, A. Zollinger, "Does Topology Control Reduce Interference", *ACM MobiHoc'2004*, pp. 9-19.
- [9] Y. Liu and E. Knightly, "Opportunistic Fair Scheduling Over Multiple Wireless Channels"; *IEEE INFOCOM 2003*.